

7. Ford-Fulkerson Demo

Ford-Fulkerson Algorithm

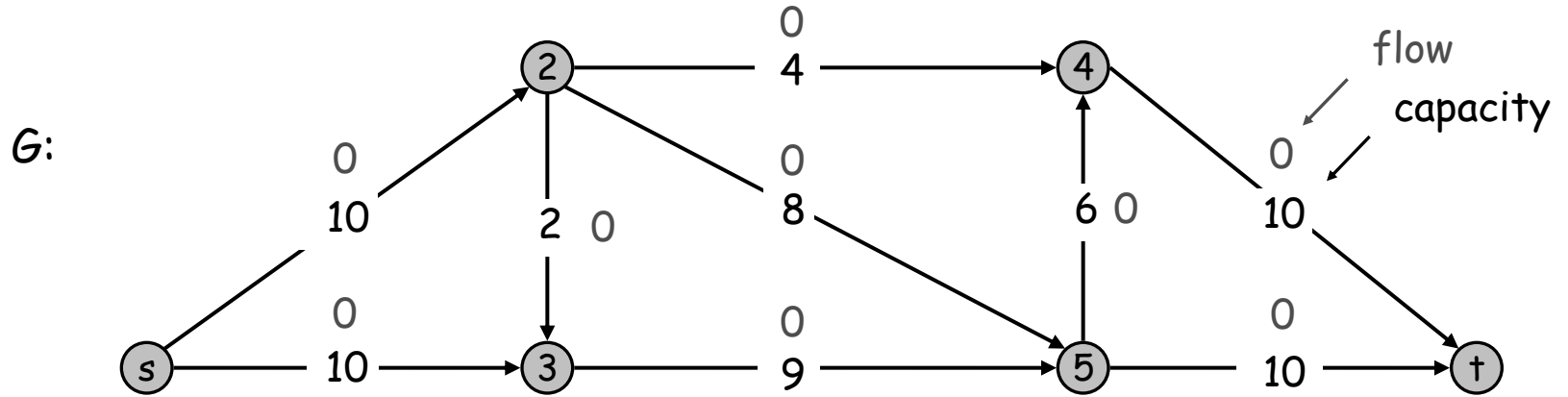

Flow value = 0

Ford-Fulkerson Algorithm

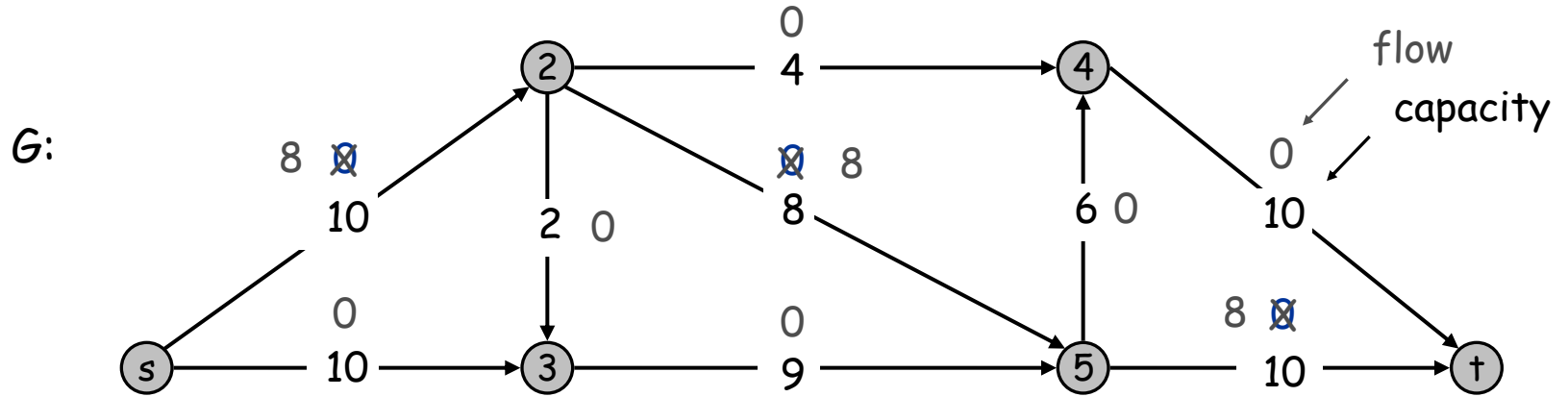

Flow value = 0

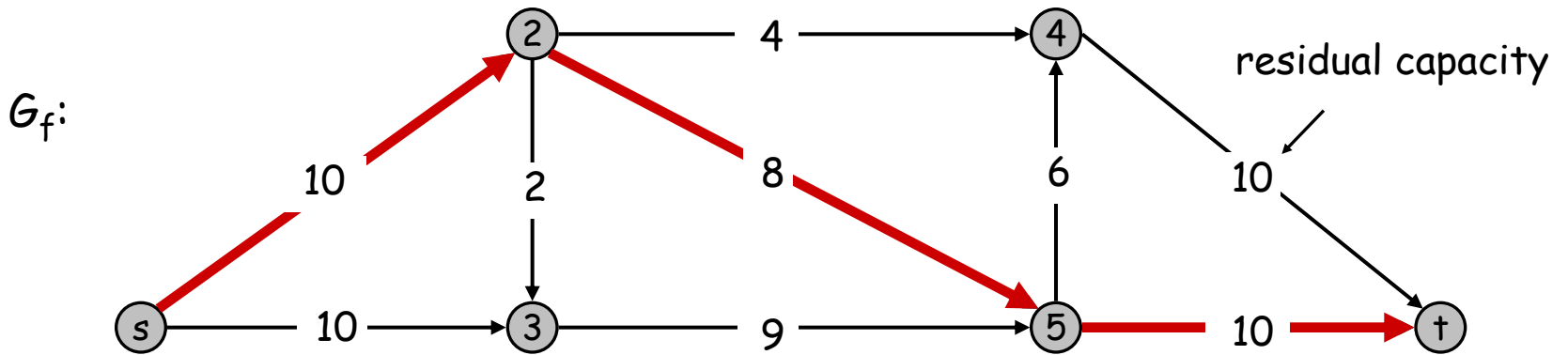

Ford-Fulkerson Algorithm

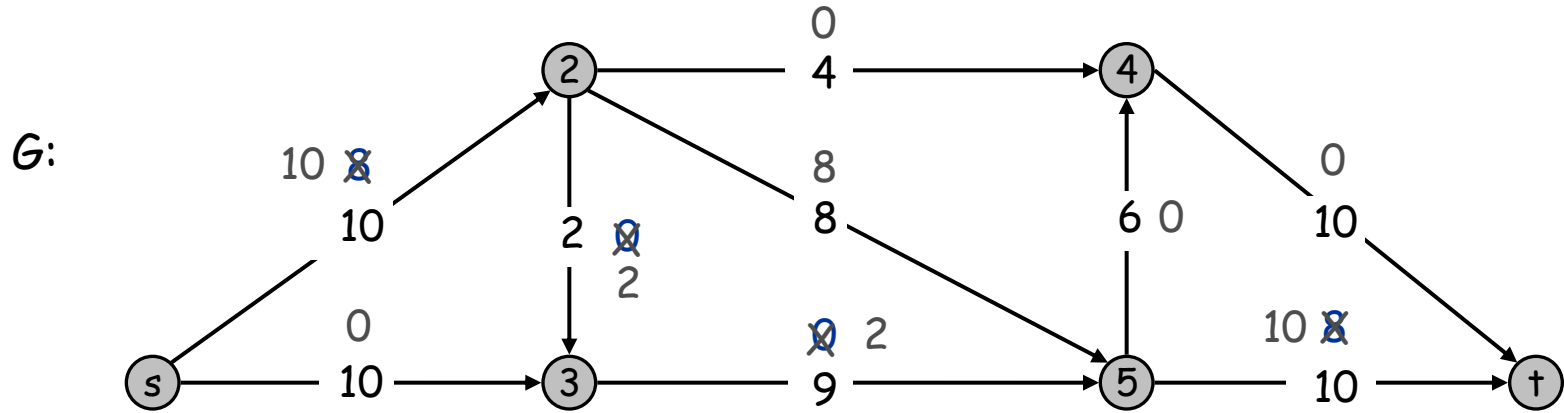

Flow value = 8

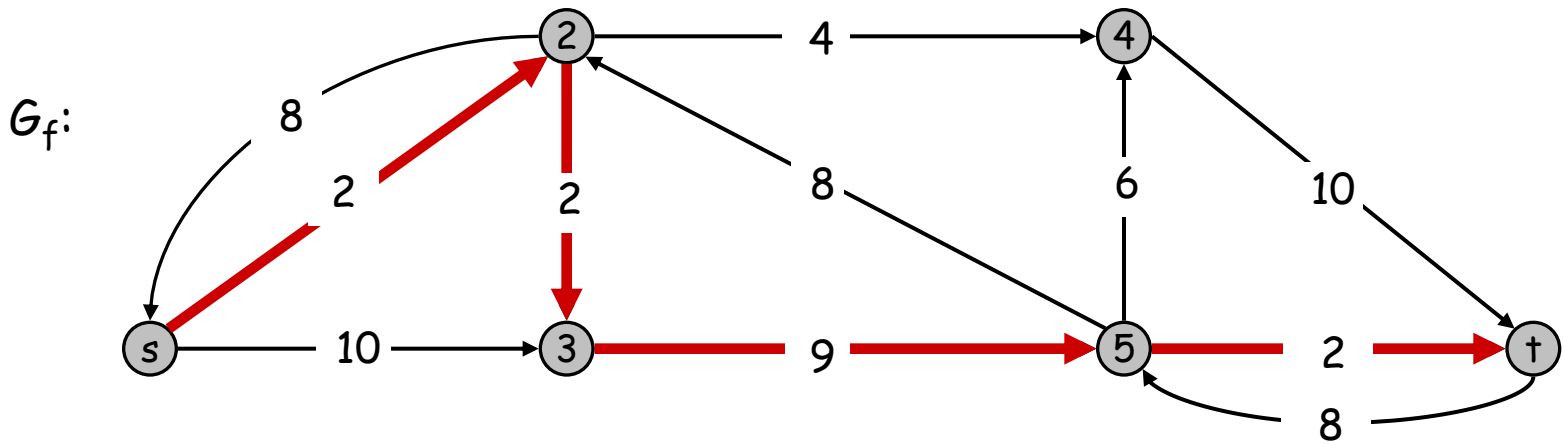

Ford-Fulkerson Algorithm

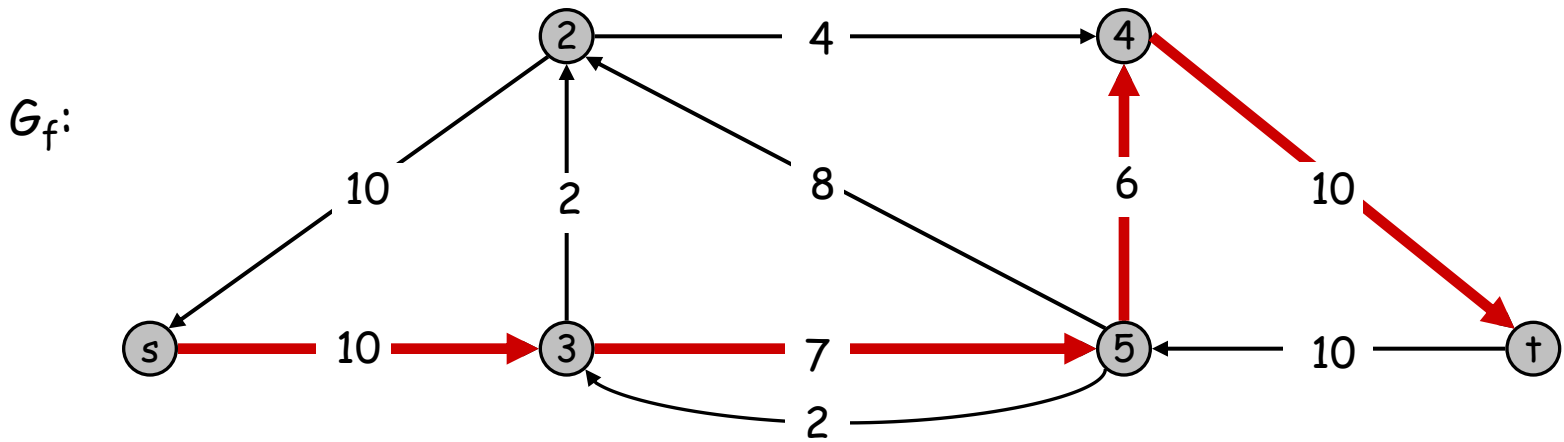
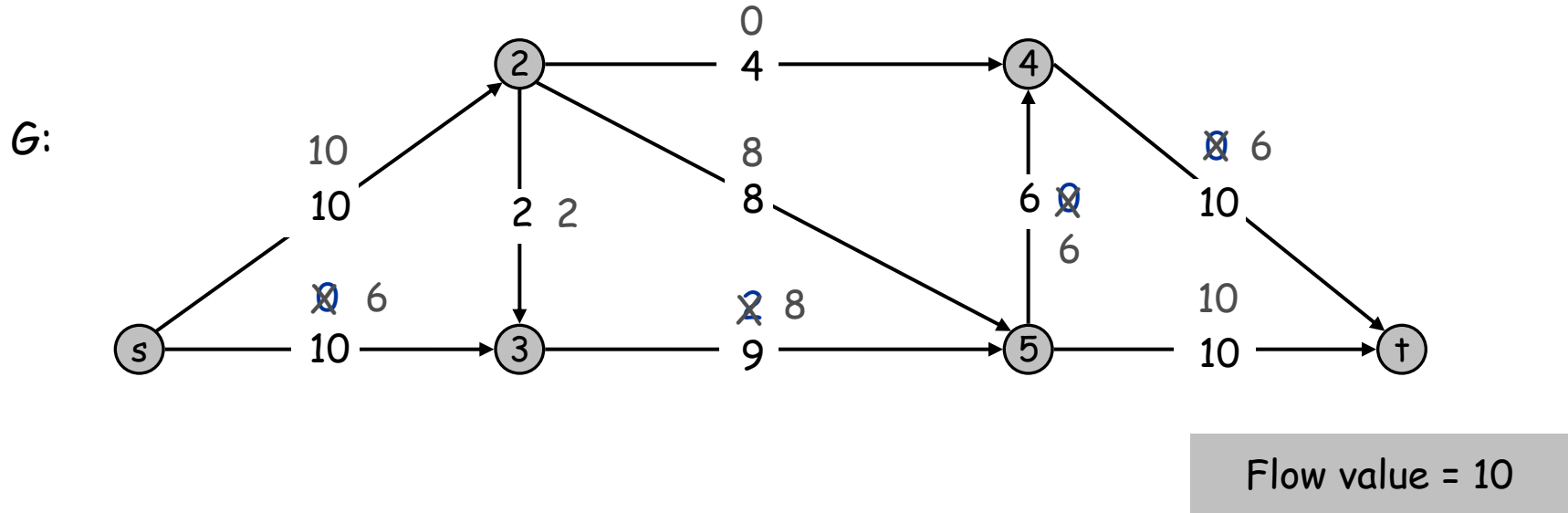

Ford-Fulkerson Algorithm

G :

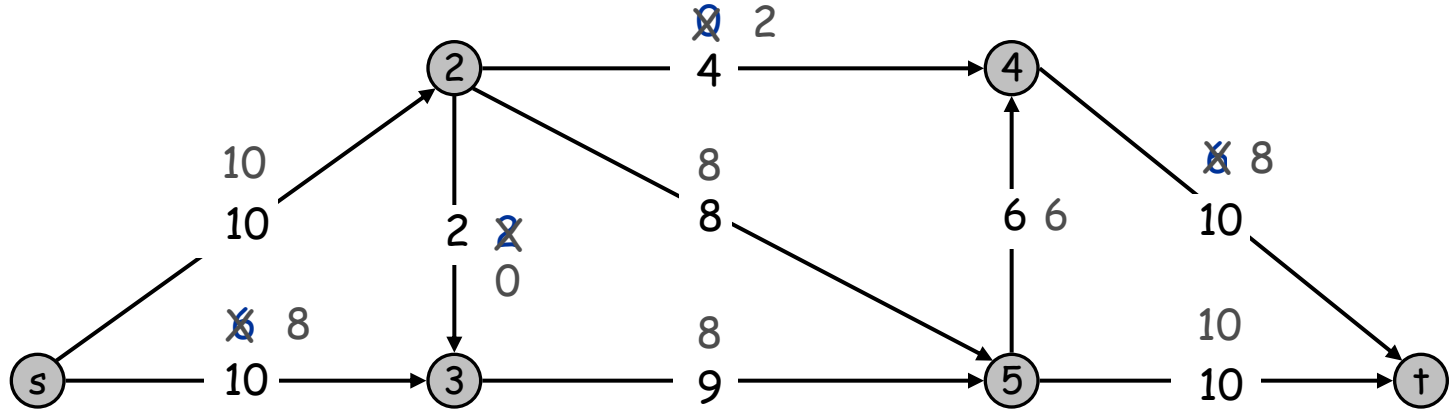

Flow value = 16

G_f :

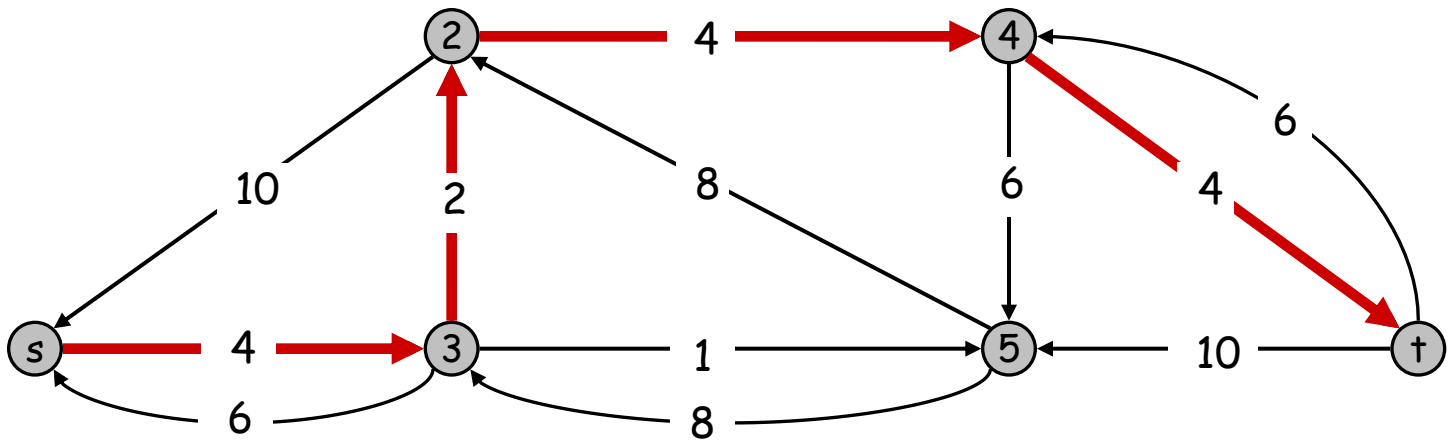

Ford-Fulkerson Algorithm

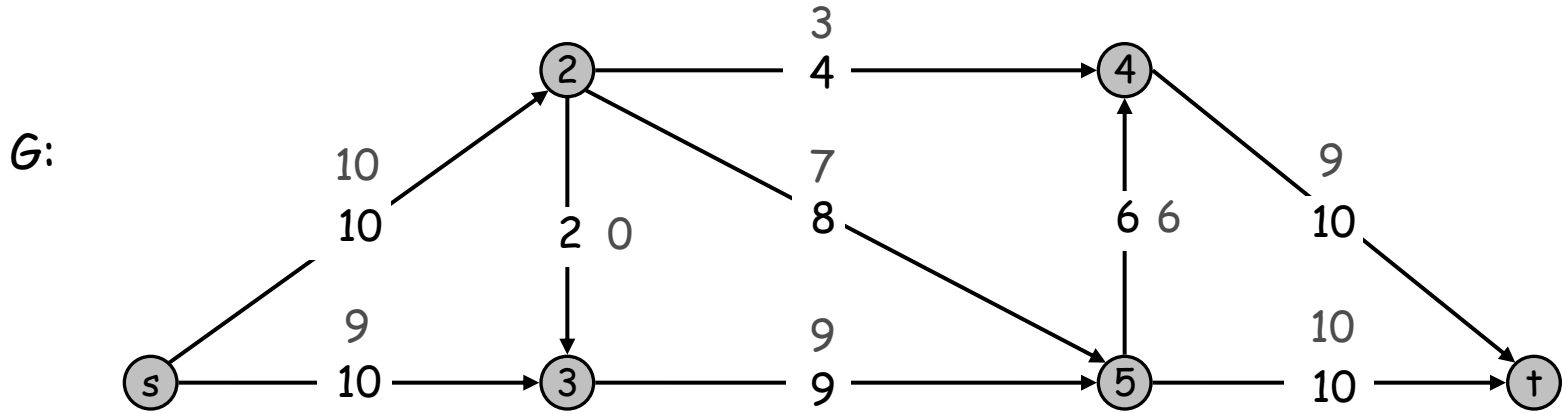

Flow value = 19

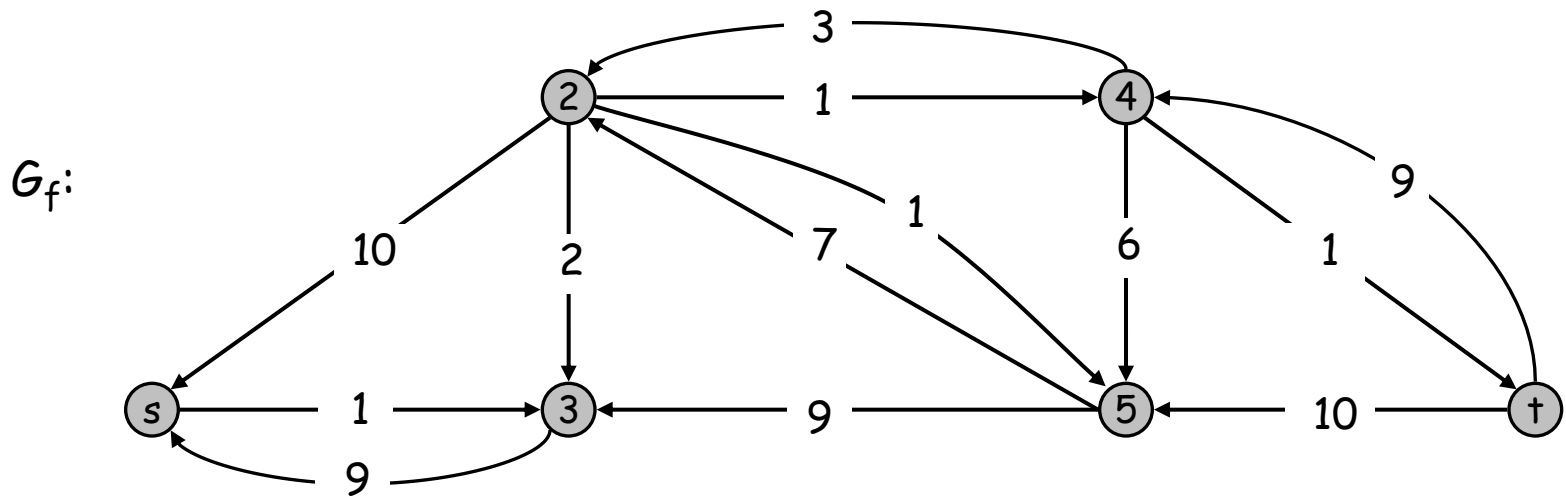

Ford-Fulkerson Algorithm

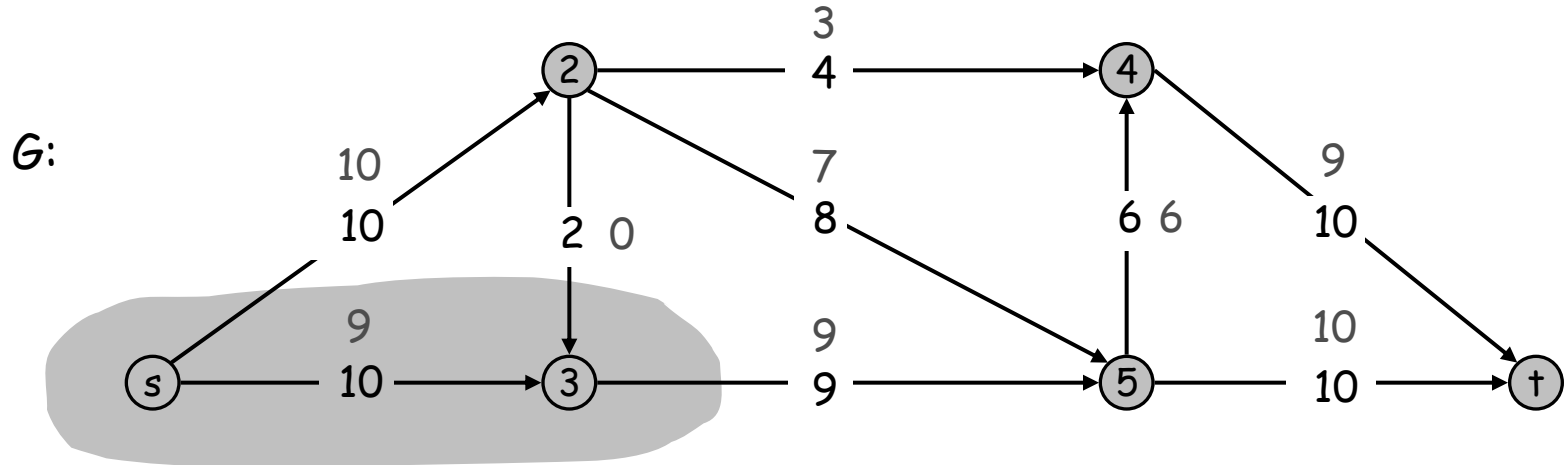

Cut capacity = 19

Flow value = 19

